

ROYAL SERIES

135° Glass to Glass Hinge Cat No. ROY - 135

RECOMMENDATIONS:

For public safety, use of only tempered safety glass. Do not use power tools when installing these hinges.

MAINTENANCE GUIDELINES:

You should never apply an abrasive cleaner on hardware. Drying the hardware with a soft towel after each use is the most effective way to get the most out of our hardware. To clean our hardware a little bit of mild dish soap and warm water should be applied using a non-abrasive cloth or towel. Rinse with clean warm water and then dry. Doing this after each use will ensure the longest life possible for the hardware. Leave the shower door slightly open to allow air to circulate; this will discourage the growth of mildew. Another important cleaning technique for shower doors is to squeegee after showering. It removes excess moisture from the shower and avoids water spots that can be difficult and almost impossible to remove. A plastic squeegee is best because metal could damage a shower.

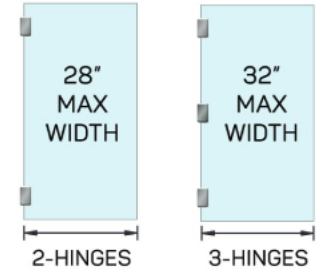
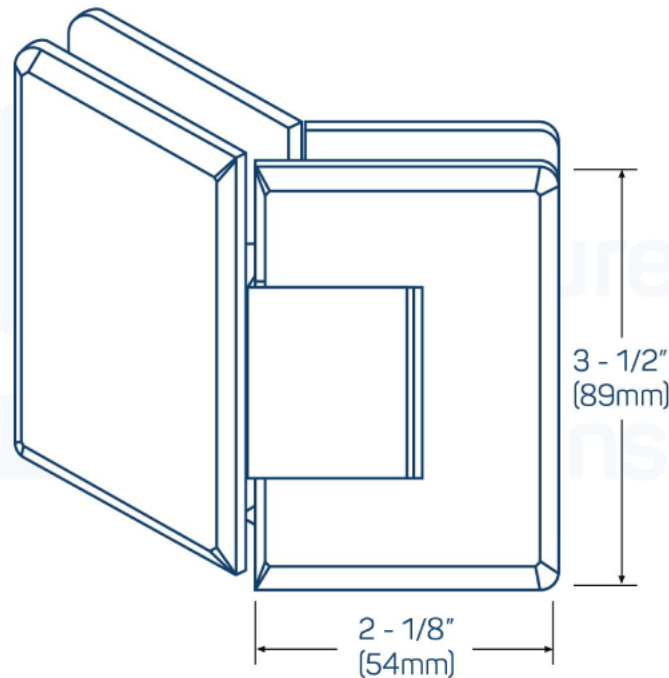

SEE TEMPLATE ON BACK
Refer to Dimensions Shown to Ensure Accuracy

MAXIMUM DOOR CAPACITY	3/8" (10 MM) GLASS		1/2" (12 MM) GLASS	
	WEIGHT	WIDTH	WEIGHT	WIDTH
USING 2 HINGES	80 LBS (36 Kg)	28" (711 mm)	80 LBS. (36 Kg)	28" (711 mm)
USING 3 HINGES	120 LBS (55 Kg)	32" (813 mm)	120 LBS. (55 Kg)	32" (813 mm)

Note: Do not exceed either maximum weight or width when choosing proper quantity of hinges.

SPECIFICATIONS

Glass Sizes: 3/8" (10mm) to 1/2" (12mm) thick tempered safety glass
 Construction: Solid brass
 Closing Type: Self-centering when within 15° of closed position
 Cutout Required
 Includes: Gaskets, screws and template

Use of Gaskets:

For 3/8"(10mm) Glass: Use one thick gasket on each side
 For 1/2"(12mm) Glass: Use one thin gasket on each side

